

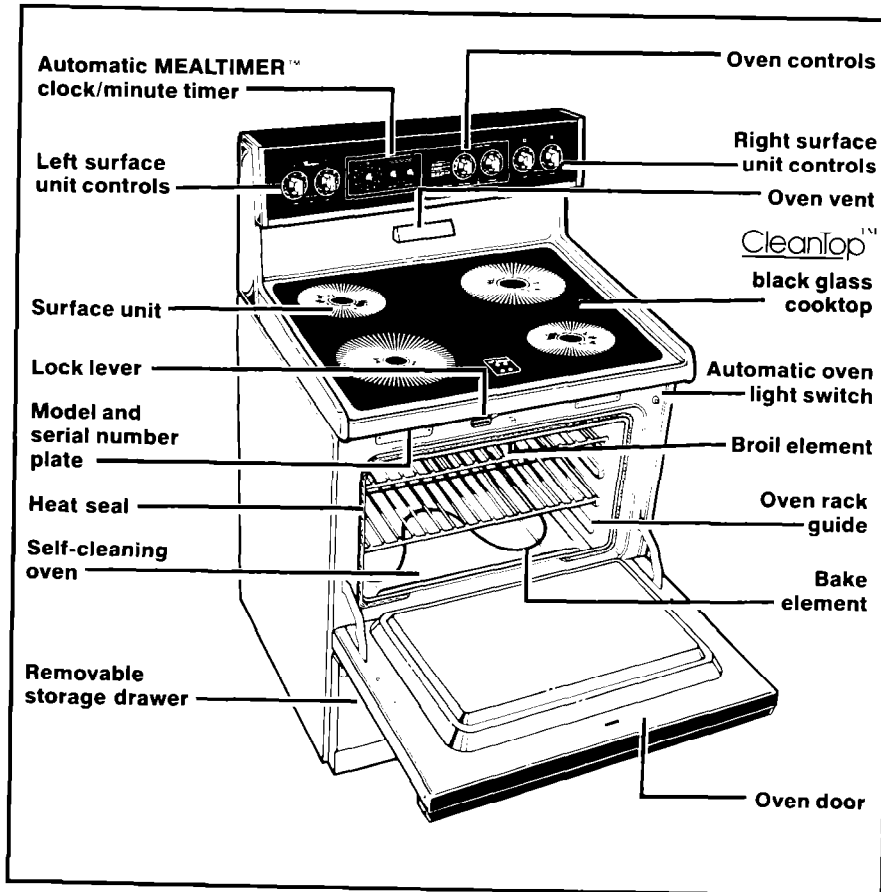

# Use & Care Guide



**SELF-CLEANING DESIGNERSTYLE™  
ELECTRIC RANGE  
RF366BXV**

# Contents

	Page
<b>Important Safety Instructions</b> .....	3
<b>Using Your Range</b> .....	5
Using the surface units .....	5
Setting the clock .....	7
Using the Minute Timer .....	7
Using the oven controls .....	8
Using the automatic MEALTIMER™ clock .....	11
The oven vent .....	13
The storage drawer .....	13
Optional rotisserie .....	14
Optional door panel pac .....	14
<b>Caring for Your Range</b> .....	15
Control panel and knobs .....	15
Cooktop .....	15
Using the Self-Cleaning cycle ..	17
Cleaning tips .....	21
The oven light .....	22
<b>If You Need Service Or Assistance</b> .....	23
<b>Whirlpool Range Warranty</b> ....	28

©1990 Whirlpool Corporation

Remove the Consumer Buy Guide label. It will be easier to remove before the range is used. To remove any remaining glue:

- Rub briskly with thumb to make a ball, then remove.  
or
- Soak area with liquid hand dishwashing detergent before removing glue as described above.

Do not use sharp instruments, rubbing alcohol, flammable fluids or abrasive cleaners. These can damage the finish. See "Important Safety Instructions" on page 3.

**Thank you for buying a Whirlpool appliance. Please complete and mail the Owner Registration Card provided with this product.** Then complete the form below. Have this information ready if you need service or call with a question.

- Copy model and serial numbers from plate (behind the oven door on the frame) and purchase date from sales slip.
- Keep this book, the Cooking Guide and sales slip together in a handy place.

---

Model Number

---

Serial Number

---

Purchase Date

---

Service Company Phone Number

## **You are responsible for:**

- Installing and leveling the range on a floor strong enough to hold its weight, and where it is protected from the elements. (See the Installation Instructions.)
- Making sure the range is not used by anyone unable to operate it properly.
- Properly maintaining the range.
- Using the range only for jobs expected of a home range.

# Important Safety Instructions

## **⚠ WARNING**

To reduce the risk of fire, electrical shock, injury to persons, or damage when using the range, follow basic precautions, including the following:

- Read all instructions before using the range.
- Install or locate the range only in accordance with the provided Installation Instructions. It is recommended that the range be installed by a qualified installer. The range must be properly connected to electrical supply and grounded.
- Do not use the range for warming or heating the room. Persons could be burned or injured, or a fire could start.
- Do not leave children alone or unattended in area where the range is in use. They should never be allowed to sit or stand on any part of the range. They could be burned or injured.
- Do not wear loose or hanging garments when using the range. They could ignite if they touch a hot surface element or heating element and you could be burned.
- Do not repair or replace any part of the range unless specifically recommended in this manual. All other servicing should be referred to a qualified technician.
- Do not store flammable materials in or near the range. They could explode or burn.
- Do not use water on grease fires. Never pick up a flaming pan. Smother flaming pan on cooktop by covering with a well-fitted lid, cookie sheet or flat tray. Flaming grease outside of pan can be extinguished with baking soda or, if available, a multipurpose dry chemical or foam-type extinguisher.
- Use only dry potholders. Moist or damp potholders on hot surfaces may result in burns from steam. Do not let potholder touch hot heating elements. Do not use a towel or bulky cloth for a potholder. They could catch on fire.
- Select a pan with a flat bottom that is about the same size as the surface unit. If pan is smaller than the surface unit, some of the heating element will be exposed and may result in the igniting of clothing or potholders. Correct pan size also improves cooking efficiency.
- Never leave surface units unattended at high heat settings. A boil-over could result and cause smoking and greasy spill-overs that may ignite.
- Check to be sure glass cooking utensils are safe for use on the cooktop. Only certain types of glass, glass ceramic, ceramic, earthenware or other glazed utensils are suitable for cooktops without breaking due to the sudden change in temperature.
- Turn pan handles inward, but not over other surface units. This will help reduce the chance of burns, igniting of flammable materials, and spills due to bumping of the pan.
- Use care when opening oven door. Let hot air or steam escape before removing or replacing food.
- Do not heat unopened containers. They could explode. The hot contents could cause burns and container particles could cause injury.
- Keep range vents unobstructed.
- Always position oven racks in desired location while oven is cool. If rack must be moved while oven is hot, do not let potholder contact hot heating element in oven.

## Important Safety Instructions Continued

- Do not clean door seal. It is essential for a good seal. Care should be taken not to rub, damage, or move the seal. Clean only parts recommended in this Use and Care Guide.
- Do not use oven cleaners. No commercial oven cleaner or oven liner protective coating of any kind should be used in or around any part of the oven.
- Before self-cleaning the oven, remove broiler pan, broiler grid, oven racks and other utensils. Do not use your oven to clean miscellaneous parts.
- Do not cook on broken cooktop. If cooktop should break, cleaning solutions and spill-overs may penetrate the broken cooktop and create a risk of electric shock. Contact a qualified technician immediately.
- Clean cooktop with care. Some cleaners can produce noxious fumes if applied to a hot surface. If a wet paper towel is used to wipe spills on a hot cooking area, be careful to avoid steam burns.
- Do not store things children might want above the range. Children could be burned or injured while climbing on it.
- Do not touch surface units, areas near surface units, heating elements or interior surfaces of oven. Surface units and heating elements may be hot even though they are dark in color. Areas near surface units and interior surfaces of an oven become hot enough to cause burns. During and after use, do not touch, or let clothing or other flammable materials contact surface units, areas near elements, heating units or interior surfaces of oven until they have had sufficient time to cool. Other surfaces of the range may become hot enough to cause burns; such as, the oven vent opening, the surface near the vent opening, the cooktop, and the oven door.

• **FOR YOUR SAFETY •**  
**DO NOT STORE OR USE**  
**GASOLINE OR OTHER**  
**FLAMMABLE VAPORS AND**  
**LIQUIDS IN THE VICINITY OF**  
**THIS OR ANY OTHER**  
**APPLIANCE. THE FUMES**  
**CAN CREATE A FIRE**  
**HAZARD OR EXPLOSION.**

– **SAVE THESE INSTRUCTIONS** –

# Using Your Range

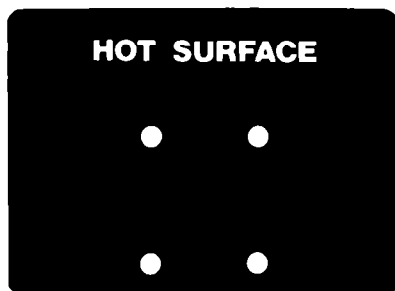
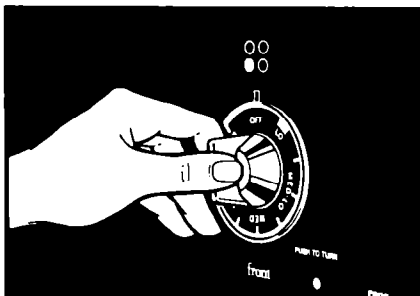

## Using the surface units

**Control knobs must be pushed in before turning** them to a setting.

They can be set anywhere between HI and OFF.

### Surface unit markers

The solid dot in the surface unit marker shows which surface unit is turned on by that knob.

### Surface unit indicator lights

One of the Surface Unit Indicator Lights on the control panel will glow when a surface unit is on.

### Hot surface indicator lights

The Hot Surface Indicator Lights on the cooktop surface will glow when the surface units are turned on. The Indicator Lights will continue to glow as long as the surface units are too hot to touch, even after they are turned off.

## **⚠ WARNING**

### **Burn and Fire Hazard**

**Be sure all control knobs are turned to OFF and all indicator lights are OFF when you are not cooking. Someone could be burned or a fire could start if a surface unit is accidentally left ON.**

## Using Your Range Continued

**Until you get used to the settings, use the following as a guide.**

For best results, start cooking at the high settings; then turn the control knob down to continue cooking.

**Use HI** to start foods cooking; to bring liquids to a boil.

**Use MED-HI** to hold a rapid boil; to fry chicken or pancakes.

**Use MED** for gravy, puddings and icing; to cook large amounts of vegetables.

**Use MED-LO** to keep food cooking after starting it on a higher setting.

**Use LO** to keep food warm until ready to serve. Set the heat higher or lower within the LO band to keep food at the temperature you want.

**NOTE:** The surface unit will glow red when it is turned on. You will see the element cycling on (glowing red) and off to maintain the proper temperature setting you have selected.

### Cookware

Use only flat-bottomed utensils on the cooktop. Pans without flat bottoms and specialty items with rounded or ridged bottoms (woks or tea kettles) will cause uneven heating and poor cooking results.

To check your cookware for flatness, place a straight-edge across the bottom of each piece. Move the straight-edge around. If light shows anywhere between the pan and the straight-edge, the pan is not flat. Do not use it.

Utensil bottoms must be clean and free from nicks and scratches. Heating a soiled pan can leave a stain on the cooktop and cause scratches.

## CAUTION

**Using a pan with a nicked or scratched bottom could damage the cooktop.**

Sliding metal pans on the cooktop surface could leave marks. Metal marks can be removed using a special cooktop polishing creme **if they are not heated**. Other marks may be permanent. See page 15 for cleaning and caring suggestions.

Wiping off the cooktop before and after each use will help keep the surface free from stains and provide the most even heating.

## Setting the clock

Push in and turn the Minute Timer Knob to set the Clock.

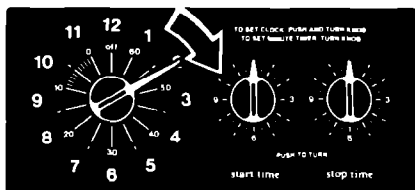

1. Push in Minute Timer Knob and turn clockwise until clock shows the right time of day.

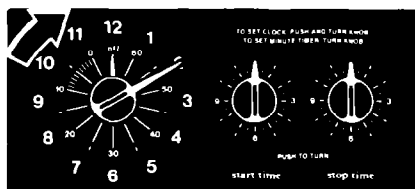

2. Let the Minute Timer Knob pop out. Turn clockwise until Minute Timer hand points to OFF. The clock setting will change if you push in the knob when turning.

## Using the Minute Timer

The Minute Timer does not start or stop the oven. It works like a kitchen timer. Set it in minutes up to an hour. You will hear a buzzer when the set time is up.

**Do not push in the knob** when setting the Minute Timer.

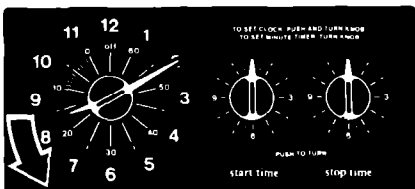

1. Without pushing it in, turn the Minute Timer Knob until the timer hand passes the setting you want.

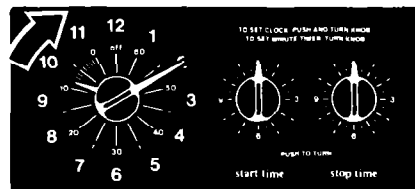

2. Without pushing in, turn the knob back to the setting you want.

**When the time is up**, a buzzer will sound. To stop the buzzer, turn the Minute Timer hand to OFF.

**NOTE:** Pushing in and turning the Minute Timer Knob changes the clock setting.

## Using Your Range Continued

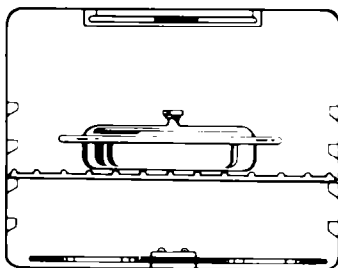
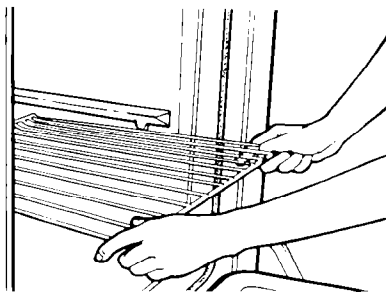

## Using the oven controls

### Baking

1. Position the rack(s) properly **before** turning on the oven. **To change rack position**, lift rack at front and pull out.

The rack(s) should be placed so the top of the food will be centered in the oven. Always leave at least 1½ to 2 inches (4-5 cm) between the sides of the pan and the oven walls and other pans. For more information, see the Cooking Guide.

2. Set the Oven Selector on **BAKE**. The Oven ON Indicator Light will come on.
3. Set the Oven Temperature Control on the baking temperature you want. The Oven HEATING Indicator Light will come on. The oven is preheated when the Oven HEATING Indicator Light first goes off.

4. Put food in the oven.

During baking, the elements will turn on and off to keep the oven temperature at the setting. The Oven HEATING Indicator Light will turn on and off with the elements.

**The top element helps heat during baking, but does not turn red.**

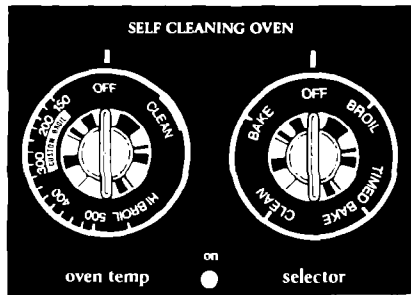

- When baking is done, turn **both** the Oven Selector and Oven Temperature Control to OFF. The Oven ON and HEATING Indicator Lights will go off.

### Adjusting the oven temperature control

Does your oven seem hotter or colder than your old oven? The temperature of your old oven may have shifted gradually without you noticing the change. Your new oven is properly adjusted to provide accurate temperatures. But when compared to your old oven, the new design may give you different results.

If, after using the oven for a period of time, you are not satisfied with the temperature settings, they can be adjusted by following these steps:

- Pull the Oven Temperature Control Knob straight off.

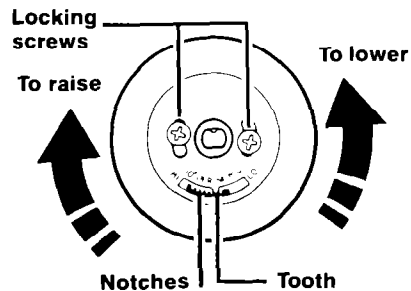
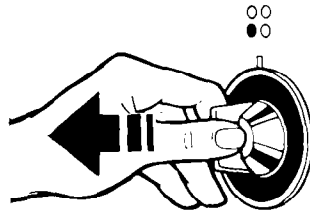

- Loosen the locking screws inside the control knob. **Note the position of the notches.**
- To lower the temperature**, move the tooth a notch closer to L.O. Each notch equals about 10°F (5°C).
- To raise the temperature**, move the tooth a notch closer to HI. Each notch equals about 10°F (5°C). **Tighten the locking screws and replace the control knob.**

## Using Your Range Continued

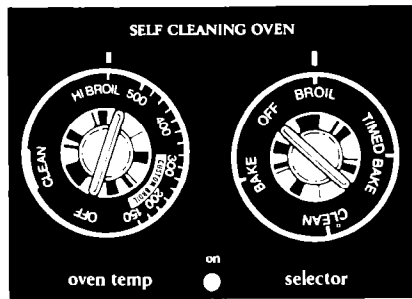
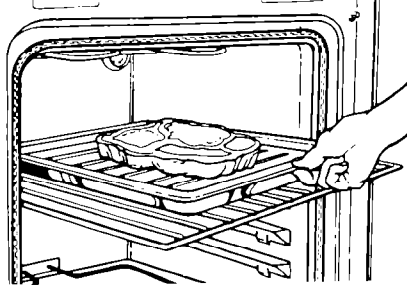

### Broiling

1. Position the rack before turning the oven on. See "Broil Chart" in the Cooking Guide or a reliable cook-book for recommended rack positions.
2. Put the broiler pan and food on the rack.
3. Close the door to the Broil Stop position (open about 4 inches, 10.2 cm). The door will stay open by itself.
4. Set the Oven Selector and Oven Temperature Control on BROIL. The Oven ON and HEATING Indicator Lights will come on.
5. When broiling is done, turn **both** the Oven Selector and Oven Temperature Control to OFF. The Oven ON and HEATING Indicator Lights will go off.

### Custom broil

- If food is cooking too fast, turn the Oven Temperature Control **counter-clockwise** until the Oven HEATING Indicator Light goes off.
- If you want the food to broil slower from the start, set the Oven Temperature Control between 150° and 325°F (65.5 and 162.7°C). The lower the temperature, the slower the cooking.

### The Oven Selector must be on BROIL for all broiling temperatures.

**NOTE:** The oven door must be partly open whenever the oven is set to BROIL. Leaving the door open allows the oven to maintain proper temperatures.

## Using the automatic MEALTIMER™ clock

The automatic MEALTIMER™ clock is designed to turn the oven on and off at times you set...even when you are not around.

Automatic baking is ideal for foods which do not require a preheated oven, such as meats and casseroles. **Do not use the automatic cycle for cakes, cookies, etc...undercooking will result.**

### To delay start and stop automatically:

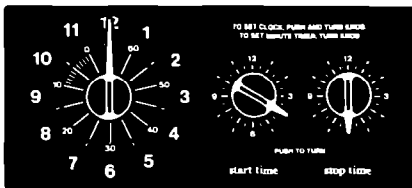
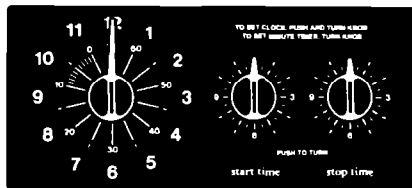

1. Position the oven rack(s) properly and place the food in the oven.
2. **Make sure the clock is set to the right time of day.**
3. Push in and turn the Start Time Knob **clockwise** to the time you want baking to start.
4. Push in and turn the Stop Time Knob **clockwise** to the time you want the oven to shut off.
5. Set the Oven Selector on TIMED BAKE. The Oven ON Indicator Light will come on.
6. Set the Oven Temperature Control on the baking temperature you want. The oven will now start and stop automatically. The Oven HEATING Indicator Light will come on.
7. **After baking is done or to stop the oven before preset time**, turn both the Oven Selector and Oven Temperature Control to OFF.

## Using Your Range Continued

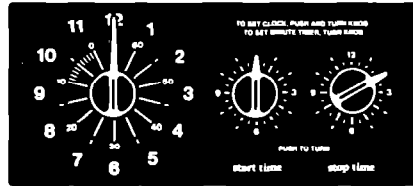

### To start baking now and stop automatically:

1. Position rack(s) properly and place the food in the oven.
2. **Make sure the clock is set to the right time of day.**
3. Push in and turn the Stop Time Knob **clockwise** to the time you want the oven to shut off. Make sure the Start Time Knob is out.
4. Set the Oven Selector on TIMED BAKE.
5. Set the Oven Temperature Control on the baking temperature you want.
6. **After baking is done or to stop the oven before the preset time,** turn both the Oven Selector and the Oven Temperature Control to OFF.

### **⚠ WARNING**

To avoid sickness and food waste when using the MEALTIMER™ control:

- Do not use foods that will spoil while waiting for cooking to start, such as dishes with milk or eggs, cream soups, and cooked meats or fish. Any food that has to wait for cooking to start should be very cold or frozen before it is put in the oven. **MOST UNFROZEN FOODS SHOULD NEVER STAND MORE THAN TWO HOURS BEFORE COOKING STARTS.**
- Do not use foods containing baking powder or yeast when using delay start. They will not rise properly.
- Do not allow food to remain in oven for more than two hours after end of cooking cycle.

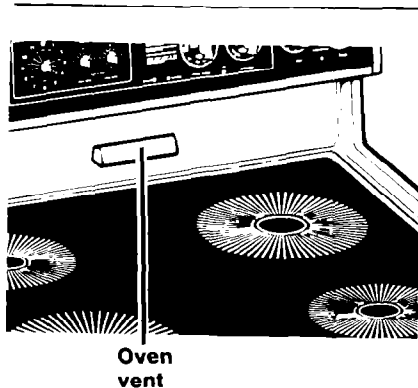

## The oven vent

Hot air and moisture escape from the oven through a vent on the backguard below the control panel. The vent is needed for air circulation. **Do not block the vent.** Poor baking can result.

### **⚠ WARNING**

#### **Burn Hazard**

**When the oven is ON, pans and pan handles left near the oven vent can become hot enough to burn the user and to melt plastics. Use potholders to move pans. Never store plastics, paper or other items that could melt or burn near the oven vent, or any of the surface units.**

## The storage drawer

The storage drawer is for storing pots and pans. The drawer can be removed to make it easier to clean under the range. **Use care when handling the drawer.**

### **Removing the storage drawer:**

1. Empty drawer of any pots and pans before removing drawer. Pull drawer straight out to the first stop. Lift front and pull out to the second stop.
2. Lift back slightly and slide drawer all the way out.

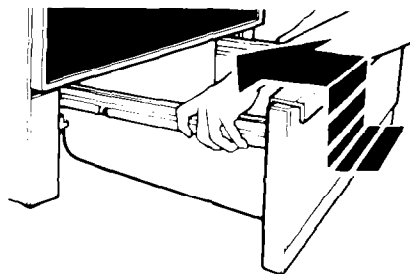
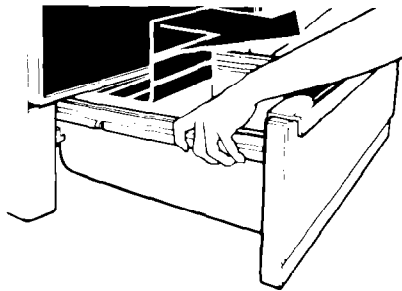

### **Replacing the storage drawer:**

1. Fit ends of drawer slide rails into the drawer guides on both sides of opening.
2. Lift drawer front and push in until metal stops on drawer slide rails clear white stops on drawer guides. Lift drawer front again to clear second stop and slide drawer closed.

## **Using Your Range Continued**

### **Optional rotisserie**

If you would like a rotisserie for your oven, you can order a kit (Part No. 242985) from your Whirlpool Dealer. The kit includes easy installation instructions.

### **Optional door panel pac**

If you would like to change the color of your oven door glass to white or almond, you can order one of these kits: White (Kit No. 814071) or Almond (Kit No. 814072) from your Whirlpool Dealer. The kits include easy installation instructions.

# Caring For Your Range

## ⚠ WARNING

**Burn and Electrical Shock Hazard**  
Make sure all controls are OFF and the range is cool before cleaning. Failure to do so can result in burns or electrical shock.

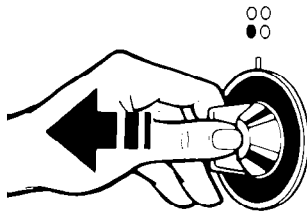

### Control panel and knobs

1. Pull control knobs straight off.
2. Use warm soapy water and a soft cloth, or spray glass cleaner, to wipe the control panel. Rinse and wipe dry.
3. Wash control knobs in warm soapy water. Rinse well and dry. Do not soak.
4. Push control knobs straight back on. Make sure they point to OFF.

### Cooktop

Consistent cleaning is essential for maintaining the glass cooktop.

**NOTE:** Always follow these directions when cleaning the cooktop to prevent staining and damage.

#### Cleaning before cooking

- Make sure the cooktop surface is clean before using. Wipe cooktop surface with a **clean, damp paper towel**.

**NOTE:** Do not use a sponge or cloth containing soap. Soap or soil can stain the cooktop when heated.

#### Cleaning spill-overs

The longer you cook with a spill-over on the cooktop, the harder it will be to remove.

#### For light spills:

- Wipe up light spills with vinegar and a clean paper towel, when the cooktop is cool enough not to steam.

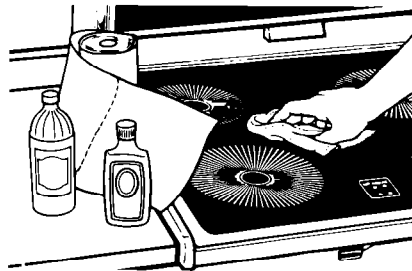

## Caring For Your Range Continued

### For heavy spills:

- Carefully scrape heavy spills using a single edge razor blade in a holder while the cooktop is still warm.

### **⚠ WARNING**

#### **Personal Injury Hazard**

- **Allow surface unit and surrounding area to reduce in temperature from hot to warm before removing heavy or sugary spills. Wear protective clothing such as oven mitts.**
- **Do not use cooktop cleaner on a hot cooktop. The cleaner may produce hazardous fumes or damage the cooktop.**
- **Do not use the range if the cooktop is cracked or broken.**

**Failure to follow these instructions can result in personal injury.**

### For sugary spills:

Sugary spills can cause pitting on the cooktop surface. Clean up sugary spills as soon as possible to avoid pitting. Clean glass while still warm.

- Carefully scrape off the spill using a single edge razor blade in a holder.
- Wipe cooktop with a clean damp paper towel. Allow cooktop to cool. Use Cooktop Polishing Creme to finish the job (see below).

### Cleaning after cooking

- For stubborn soils, keep a vinegar soaked paper towel on the stain for 10-15 minutes. Rub off soil. Rinse and dry well.
- Use Cooktop Polishing Creme included with your range. Follow instructions on the container to remove metal marks (from copper or aluminum) right away. If heated they may never come off.

- Remove areas of discoloration from mineral deposits in water and food, and dark streaks and specks from use of incorrect cleaning materials with polishing creme.
- Tiny scratches or abrasions are not removable, but do not affect cooking. In time, the scratches will become less visible as a result of cleaning.

To obtain order information for Cooktop Polishing Creme (Part No. 814009), write to:

Whirlpool Corporation  
Attention: Customer Service Dept.  
1900 Whirlpool Drive  
LaPorte, IN 46305

### **⚠ CAUTION**

**To avoid damaging the cooktop, follow these instructions:**

- **Make sure bottoms of pans are clean and dry before using.**
- **Avoid spill-overs. Use pans with tall sides.**
- **Do not allow anything that may melt (plastic, aluminum foil, sugar or food with high sugar content) to come into contact with the surface while it is hot.**
- **Do not use the cooktop as a cutting board.**
- **Do not place food directly on glass cooktop.**
- **Do not use steel wool, plastic cleaning pads, powdered cleansers, chlorine bleach, rust remover or cleaning products designed for white ceramic cooktops. These could damage the cooktop surface.**
- **Dropping heavy or hard objects on the cooktop can crack it. Be careful with heavy skillets. Don't store jars or cans above the cooktop.**

## Using the Self-Cleaning cycle

The Self-Cleaning cycle uses **very high heat** to burn away soil. Before you start, make sure you understand exactly how to use the Self-Cleaning cycle safely.

### Before you start

#### 1. Clean the areas shown by hand.

They do not get hot enough during the Self-Cleaning cycle for soil to burn away. Use hot water and detergent or a soapy steel wool pad on...

- The inside of the door. (The center area of the door does not need to be hand cleaned.)
- The frame around the oven.

**Do not** clean, move or bend the fiberglass seal. Poor cleaning and poor baking will result.

#### 2. Remove the broiler pan and any pots and pans you may have stored in the oven.

**NOTE:** The broiler pan (without grid) can be cleaned in the oven only if most of the soil has been removed by hand-cleaning or a dishwasher. The chrome broiler grid will discolor if cleaned in the Self-Cleaning cycle.

#### 3. Wipe out any loose soil or grease. This will help reduce smoke during the Self-Cleaning cycle.

#### 4. If the oven has a rotisserie, make sure the motor socket cover is closed.

#### 5. If you want the oven racks to remain shiny, remove from the oven and clean by hand. Otherwise, put oven racks on second and fourth guides (guides are counted from bottom to top). After racks are cleaned in the Self-Cleaning cycle, they become harder to slide. See page 21.

Turn on a vent hood or other kitchen vent during the Self-Cleaning cycle. This will help remove heat and odors that are normal during the cycle.

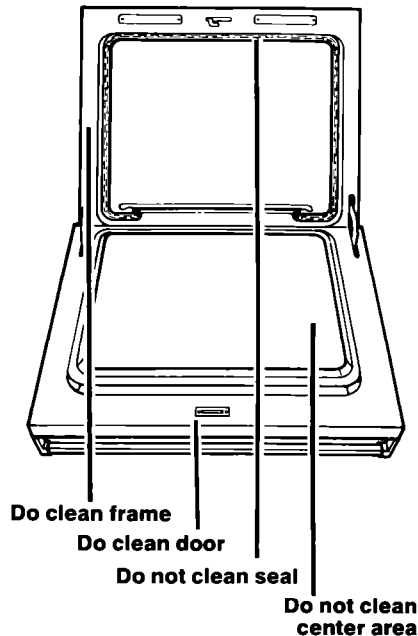

## Caring For Your Range Continued

### **⚠ WARNING**

#### **Personal Injury and Product Damage Hazard**

- Do not touch the oven during the Self-Cleaning cycle. It could burn you.
- Do not use commercial oven cleaners in your oven. Cleaners may produce hazardous fumes or damage the porcelain finish.
- Do not force the Lock Lever, you could bend or break it. The lever is designed to stay locked until the oven is cool enough to safely open. Wait until it moves freely.
- Do not use foil or other liners in the oven. During the Self-Cleaning cycle foil can burn or melt and damage the oven surface.
- Do not block the vent during the Self-Cleaning cycle. Air must move freely for best cleaning results.
- Do not leave plastic utensils near the vent. They may melt.

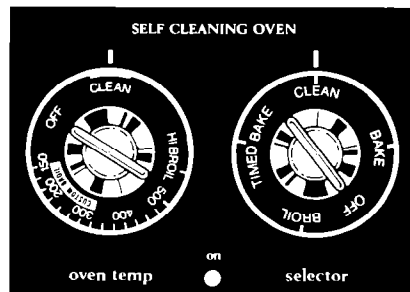

#### **Setting the controls**

1. Set the Oven Selector and Oven Temperature Control on CLEAN.

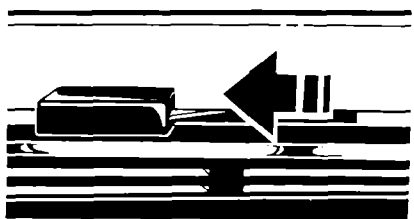
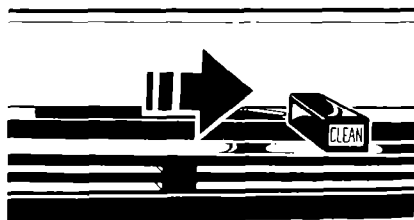
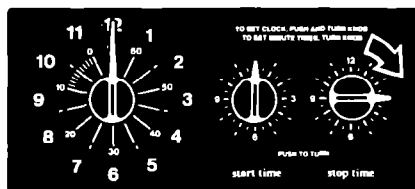

2. Make sure the Clock, Start and Stop Times all have the right time of day.
3. Push in and turn the Stop Time Knob **clockwise** 2 or 3 hours.
  - Use 2 hours for light soil.
  - Use 3 hours or more for moderate to heavy soil.

**NOTE:** Make sure the Start Time Knob is out.

4. Move the Lock Lever to the right – the Clean position. The Oven HEATING and ON Indicator Lights will come on.
5. The Oven LOCKED Indicator Light comes on when the oven temperature exceeds normal baking temperatures. The Lock Lever must not be moved and the door can't be opened when the Oven LOCKED Indicator Light is on.
6. **After the Self-Cleaning cycle is completed**, the Oven LOCKED Indicator Light goes off when the oven reaches normal baking temperatures. Move the Lock Lever back to the left. **Do not force it.** Wait until it moves easily. Turn the Oven Selector and Oven Temperature Control to OFF.
7. **After the oven is cool**, wipe off any residue or ash with a damp cloth. If needed, touch up spots with a soapy steel wool pad.

#### Special tips

- Keep the kitchen well ventilated during the Self-Cleaning cycle to help get rid of heat, odors and smoke.
- Clean the oven before it gets heavily soiled. Cleaning a very soiled oven takes longer and results in more smoke than usual.
- If the Self-Cleaning cycle doesn't get the oven as clean as you expected, the cycle may not have been set long enough or you may not have prepared the oven properly. Set the Self-Cleaning cycle longer the next time and hand clean areas noted on page 17.

## Caring For Your Range Continued

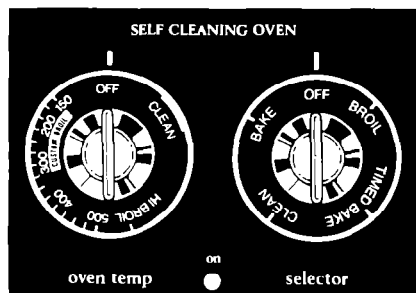
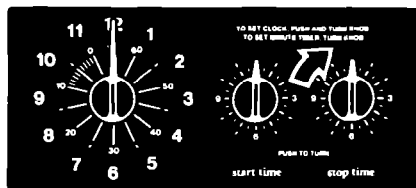

### To stop the Self-Cleaning cycle at any time:

1. Push in and turn the Stop Time Knob **clockwise** until it points to the right time of day.
2. Turn the Oven Selector and Oven Temperature Control to OFF. When the Oven LOCKED Indicator Light goes off, move the Lock Lever back to the left. **Do not force it.** Wait until it moves easily.

### How it works

During the Self-Cleaning cycle, the oven gets much hotter than it does for baking or broiling... approximately 875°F (468°C). This heat breaks up grease and soil and burns it off.

This graph shows approximate temperatures and times during a Self-Cleaning cycle for 3 hours.

### Self-Cleaning cycle – three hour setting

(Approximate temperatures and times)

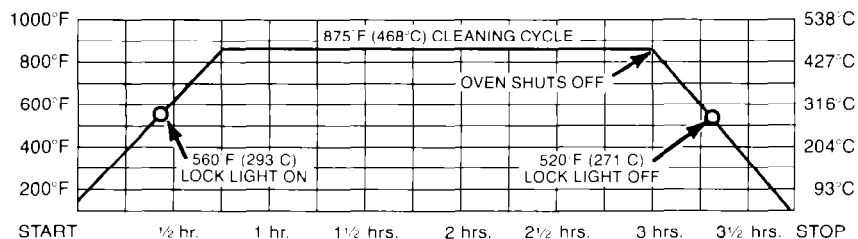

Notice that the heating stops when the 3-hour setting is up, but that it takes longer for the oven to cool down enough to unlock.

## Cleaning tips

### Control knobs

Clean with warm soapy water and a soft cloth.

- Wash, rinse and dry well.
- Do not soak.

### Control panel

Clean with warm soapy water or spray glass cleaner and a soft cloth.

- Wash, rinse and dry well.
- Follow directions provided with the cleaner.

### Black-glass cooktop

See pages 15 and 16 for cleaning instructions.

### Oven exterior

Clean with warm soapy water and a soft cloth.

- Wipe off regularly when cooktop and oven are cool.

Use a plastic scrubbing pad for heavily-soiled areas.

- Do not use abrasive or harsh cleaners.

**NOTE:** Do not allow food containing acids (such as vinegar, tomato, lemon juice or milk) to remain on surface. Acids may remove the glossy finish.

### Broiler pan and grid

Clean with warm soapy water or a soapy steel wool pad.

- Clean after each use.
- Wash, rinse and dry well.
- Do not clean in Self-Cleaning Oven. (See note on page 17.)

### Oven racks

Use Self-Cleaning cycle.

- Leave in oven during Self-Cleaning cycle.

#### OR

Clean with warm soapy water or soapy steel wool pads.

- Wash, rinse and dry. Use soapy steel wool pads for heavily-soiled areas.

**NOTE:** The oven racks will discolor and be harder to slide when left in the oven during the Self-Cleaning cycle. If you want them to stay shiny, remove from the oven and clean by hand. If racks are left in the oven during the Self-Cleaning cycle, apply a small amount of vegetable oil to the sides of the racks to make them easier to slide.

### Oven door glass

Use spray glass cleaner or warm soapy water and a plastic scrubbing pad.

- Make sure oven is cool.
- Follow directions provided with the cleaner.
- Wash, rinse and dry well.

### Self-Cleaning oven

For areas outside the Self-Cleaning area use warm soapy water or soapy steel wool pads.

- Follow directions starting on page 17, "Using the Self-Cleaning cycle."
- Do not use commercial oven cleaners.
- Do not use foil to line the bottom of your Self-Cleaning Oven.

## The oven light

The oven light will come on when you open the oven door.

### **⚠ WARNING**

#### **Electrical Shock and Personal Injury Hazard**

- **Make sure oven and light bulb are cool and power to the oven has been turned OFF before replacing the light bulb. Failure to do so could result in electrical shock or burns.**
- **The bulb cover must be in place when using the oven. The cover protects the bulb from breaking, and from high oven temperatures. Broken glass could cause injury.**

#### **To replace the oven light:**

1. Unplug appliance or disconnect at main power supply.
2. Remove the bulb cover in the back of the oven by pulling out and pushing the wire holder to the side.
3. Remove the light bulb from its socket. Replace the bulb with a 40 watt appliance bulb.
4. Replace the bulb cover and snap the wire holder in place. Plug in appliance or re-connect at main power supply.  
**NOTE:** The oven light will not work during the Self-Cleaning cycle.

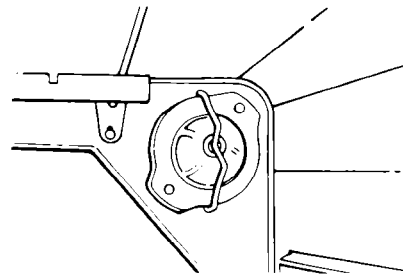
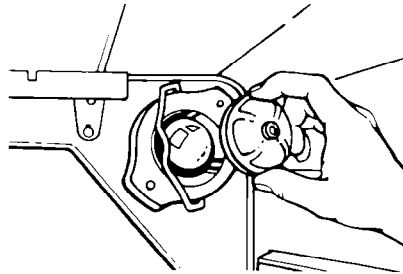

# If You Need Service Or Assistance

## We suggest you follow these steps:

### 1. Before calling for assistance...

Performance problems often result from little things you can find and fix without tools of any kind.

#### If nothing operates:

- Is the power supply cord plugged into a live circuit with the proper voltage? (See Installation Instructions.)
- Have you checked your home's main fuses or circuit breaker box?

#### If the oven will not operate:

- Is the Oven Selector turned to a setting (BAKE or BROIL, but not TIMED BAKE)?
- Is the Oven Temperature Control turned to a temperature setting?
- Is the automatic MEALTIMER™ clock set correctly?

#### If surface units will not operate:

- Have you checked your home's main fuses or circuit breaker box?
- Do the control knobs turn?

#### If surface unit knob(s) will not turn:

- Did you push in before trying to turn?

#### If the Self-Cleaning cycle will not operate:

- Are the Oven Selector and Oven Temperature Control set on CLEAN?

- Does the Start Time Dial show the right time of day? Is the knob all the way out?
- Is the Stop Time Dial set ahead to the time you want the Self-Cleaning cycle to stop?
- Is the Lock Lever all the way to the right?

#### If cooking results aren't what you expected:

- Is the range level?
- Does the oven temperature seem too low or too high? See page 9.
- If needed, have you preheated the oven as the recipe calls for?
- Are you following a tested recipe from a reliable source?
- Are you using pans recommended in the Cooking Guide?
- If baking, have you allowed 1½ to 2 inches (4-5 cm) on all sides of the pans for air circulation?
- Are the pans the size called for in the recipe?
- Do the cooking utensils have smooth, flat bottoms and fit the surface elements being used?

See the Cooking Guide for more information on cooking problems and how to solve them.

## If You Need Service Or Assistance Continued

### 2. If you need assistance\*...

**Call Whirlpool COOL-LINE® service assistance telephone number. Dial free from anywhere in the U.S.: 1-800-253-1301**

and talk with one of our trained consultants. The consultant can instruct you in how to obtain satisfactory operation from your appliance or, if service is necessary, recommend a qualified service company in your area.

If you prefer, write to:

Mr. Donald Skinner  
Director of Consumer Relations  
Whirlpool Corporation  
2000 M-63  
Benton Harbor, MI 49022

Please include a daytime phone number in your correspondence.

### 3. If you need service\*...



Whirlpool has a nationwide network of authorized Whirlpool<sup>SM</sup> service com-

panies. Whirlpool service technicians are trained to fulfill the product warranty and provide after-warranty service, anywhere in the United States. To locate the authorized Whirlpool service company in your area, call our COOL-LINE® service assistance telephone number (see Step 2) or look in your telephone directory Yellow Pages under:

APPLIANCES - HOUSEHOLD - MAJOR - SERVICE & REPAIR      ELECTRICAL APPLIANCES - MAJOR - REPAIRING & PARTS  
**OR**  
WASHING MACHINES, DRYERS & IRONERS - SERVICING  
WHIRLPOOL APPLIANCES  
AUTHORIZED WHIRLPOOL SERVICE  
*SERVICE COMPANIES*  
XYZ SERVICE CO      999-9999  
123 MAPLE

### 4. If you need FSP replacement parts\*...

FSP is a registered trademark of Whirlpool Corporation for quality parts. Look for this symbol of quality whenever you need a replacement part for your Whirlpool appliance. FSP replacement parts will fit right and work right, because they are made to the same exacting specifications used to build every new Whirlpool appliance.

To locate FSP replacement parts in your area, refer to Step 3 above or call the Whirlpool COOL-LINE service assistance number in Step 2.

### 5. If you are not satisfied with how the problem was solved\*...

- Contact the Major Appliance Consumer Action Panel (MACAP). MACAP is a group of independent consumer experts that voices consumer views at the highest levels of the major appliance industry.
- Contact MACAP only when the dealer, authorized servicer or Whirlpool have failed to resolve your problem.  
Major Appliance Consumer Action Panel  
20 North Wacker Drive  
Chicago, IL 60606
- MACAP will in turn inform us of your action.

\*When requesting assistance, please provide: model number, serial number, date of purchase, and a complete description of the problem. This information is needed in order to better respond to your request.







# Whirlpool® Range Product Warranty

ER001

LENGTH OF WARRANTY	WHIRLPOOL WILL PAY FOR
<b>FULL ONE-YEAR WARRANTY</b> From Date of Purchase	FSP® replacement parts and repair labor to correct defects in materials or workmanship. Service must be provided by an authorized Whirlpool <sup>SM</sup> service company.
WHIRLPOOL WILL NOT PAY FOR	
<p><b>A.</b> Service calls to:</p> <ol style="list-style-type: none"><li>1. Correct the installation of the range product.</li><li>2. Instruct you how to use the range product.</li><li>3. Replace house fuses or correct house wiring or plumbing.</li><li>4. Replace owner accessible light bulbs.</li></ol> <p><b>B.</b> Repairs when range product is used in other than normal, single-family household use.</p> <p><b>C.</b> Pick up and delivery. This product is designed to be repaired in the home.</p> <p><b>D.</b> Damage to range product caused by accident, misuse, fire, flood, acts of God or use of products not approved by Whirlpool.</p>	

WHIRLPOOL CORPORATION SHALL NOT BE LIABLE FOR INCIDENTAL OR CONSEQUENTIAL DAMAGES. Some states do not allow the exclusion or limitation of incidental or consequential damages so this limitation or exclusion may not apply to you. This warranty gives you specific legal rights, and you may also have other rights which vary from state to state.

Outside the United States, a different warranty may apply. For details, please contact your franchised Whirlpool distributor or military exchange.

If you need service, first see the "Service and Assistance" section of this book. After checking "Service and Assistance," additional help can be found by calling our COOL-LINE® service assistance telephone number, **1-800-253-1301**, from anywhere in the U.S.

